MD-15

CONTENTS

| | |
|---|--------|
| 1-1 Specifications | |
| 1-1-1 Specifications | 1-1-1 |
| 1-1-2 Parts names | 1-1-2 |
| 1-1-3 Machine cross section | 1-1-3 |
| 1-1-4 Drive system | 1-1-4 |
| 1-2 Installation | |
| 1-2-1 Unpacking | 1-2-1 |
| 1-2-2 Installing the desk dehumidifier (service part) | 1-2-2 |
| 1-3 Troubleshooting | |
| 1-3-1 Paper misfeed detection | 1-3-1 |
| (1) Paper misfeed indication | 1-3-1 |
| (2) Paper misfeed detection conditions | 1-3-1 |
| (3) Paper misfeeds | 1-3-3 |
| 1-3-2 Self-diagnosis | 1-3-5 |
| (1) Self-diagnostic function | 1-3-5 |
| (2) Self-diagnostic codes | 1-3-5 |
| 1-3-3 Electrical problems | 1-3-7 |
| (1) The paper feed desk does not operate when the copier print key is pressed. | 1-3-7 |
| (2) The desk drive motor does not operate. | 1-3-7 |
| (3) The desk upper paper feed clutch does not operate. | 1-3-7 |
| (4) The desk lower paper feed clutch does not operate. | 1-3-7 |
| (5) The desk feed clutch does not operate. | 1-3-7 |
| (6) The desk upper lift motor does not operate. | 1-3-8 |
| (7) The desk lower lift motor does not operate. | 1-3-8 |
| (8) The bypass paper feed clutch does not operate. | 1-3-8 |
| (9) The size of paper in the lower drawer is not displayed correctly. | 1-3-8 |
| (10) The message requesting covers to be closed is displayed when the desk left cover is closed. | 1-3-9 |
| (11) Others. | 1-3-9 |
| 1-3-4 Mechanical problems | 1-3-10 |
| (1) No paper feed. | 1-3-10 |
| (2) Skewed paper feed. | 1-3-10 |
| (3) Multiple sheets of paper are fed at one time. | 1-3-10 |
| (4) Paper jams. | 1-3-10 |
| (5) Abnormal noise is heard. | 1-3-10 |
| 1-4 Assembly and Disassembly | |
| 1-4-1 Precautions for assembly and disassembly | 1-4-1 |
| (1) Precautions | 1-4-1 |
| 1-4-2 Paper feed section | 1-4-2 |
| (1) Detaching and refitting the forwarding, paper feed and separation pulleys | 1-4-2 |
| (2) Replacing the desk upper or lower paper width switches | 1-4-4 |
| (3) Replacing the desk feed, upper and lower paper feed clutches | 1-4-5 |
| (4) Adjusting the position of the rack adjuster | 1-4-7 |
| (5) Adjusting the amount of slack. | 1-4-8 |
| 2-1 Mechanical construction | |
| 2-1-1 Mechanical construction | 2-1-1 |
| 2-2 Electrical Parts Layout | |
| 2-2-1 Electrical parts layout | 2-2-1 |
| 2-3 Operation of the PCBs | |
| 2-3-1 Desk main PCB | 2-3-1 |

2-4 Appendixes

| | |
|--------------------------|-------|
| Timing chart No. 1 | 2-4-1 |
| Timing chart No. 2 | 2-4-2 |
| Wiring diagram | 2-4-3 |

1-1-1 Specifications

| | |
|--------------------|---|
| Paper | Plain paper (75 – 80 g/m ²) |
| Paper size | A3 – A5R, folio, 11" × 17" – 5 ¹ / ₂ " × 8 ¹ / ₂ " |
| Capacity | 550 sheets |
| Power source | Electrically connected to the copier. |
| Dimensions | 585 (W) × 590 (D) × 315 (H) mm 23 ¹ / ₁₆ " (W) × 23 ¹ / ₄ " (D) × 12 ³ / ₈ " (H) |
| Weight | 25 kg/55 lbs |

1-1-2 Parts names

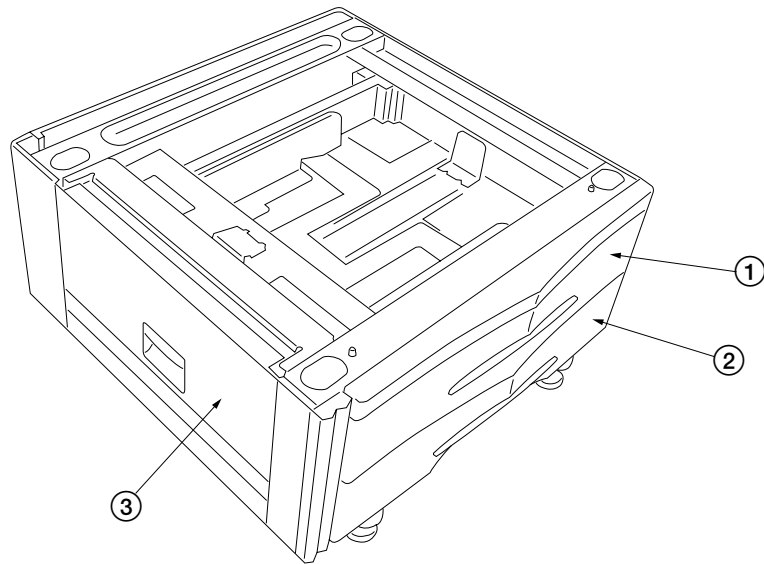

Figure 1-1-1

- ① Upper drawer
- ② Lower drawer
- ③ Desk left cover

1-1-3 Machine cross section

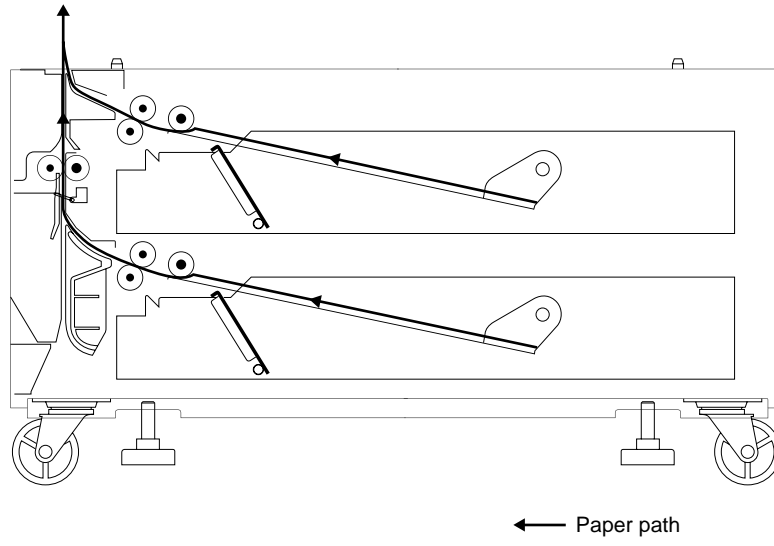
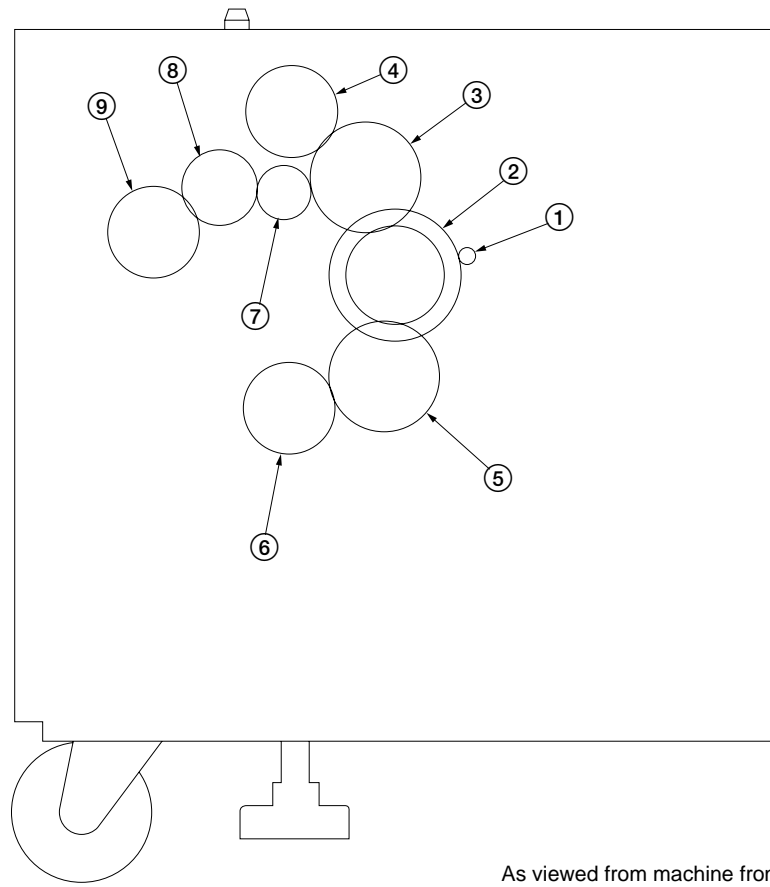

Figure 1-1-2 Machine cross section

1-1-4 Drive system



As viewed from machine front

Figure 1-1-3 Drive system

- | | |
|-------------------------------------|-------------------------------------|
| ① Desk drive motor gear | ⑥ Desk lower paper feed clutch gear |
| ② Idle gear 67/34 | ⑦ Gear 20 |
| ③ Gear 41 | ⑧ Gear 26 |
| ④ Desk upper paper feed clutch gear | ⑨ Desk feed clutch gear |
| ⑤ Gear 41 | |

1-2-1 Unpacking

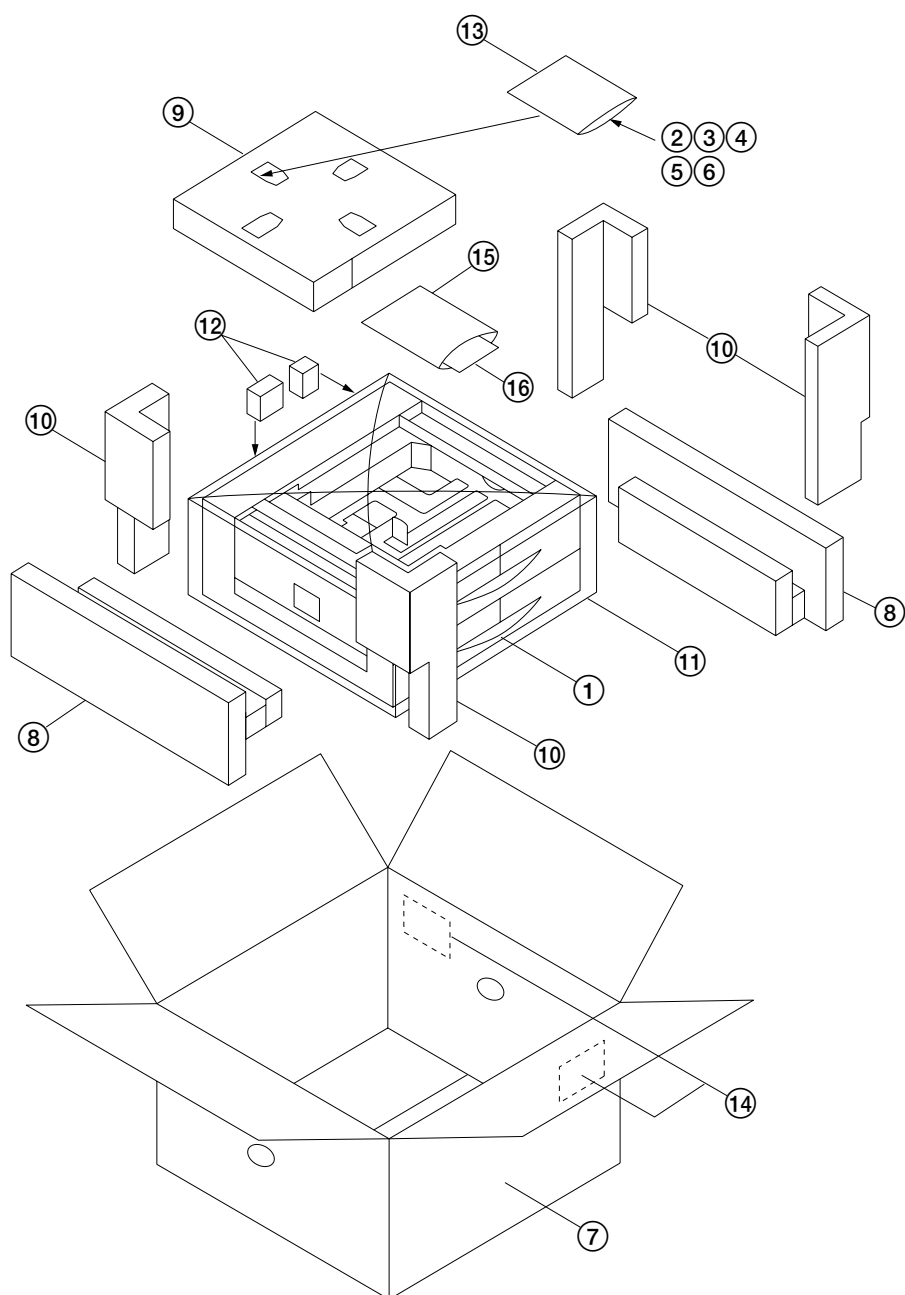

Figure 1-2-1

- | | |
|--|----------------------|
| ① Paper feed desk | ⑨ Upper pad |
| ② Retainer | ⑩ Stays |
| ③ Cross-head chromate binding screws, CVM4 × 06 | ⑪ Machine cover |
| ④ Pins | ⑫ Rear spacer |
| ⑤ Stays | ⑬ Plastic bag |
| ⑥ Chrome TP screws, M4 × 10 | ⑭ Bar code label |
| ⑦ Outer case | ⑮ Plastic bag |
| ⑧ Bottom pads | ⑯ Installation guide |

1-2-2 Installing the desk dehumidifier (service part)

Desk dehumidifier installation requires the following parts:
 Desk dehumidifier (P/N 33960020): for 220 – 240 V specifications only
 Desk dehumidifier (P/N 34860030): for 120 V specifications only
 Two (2) M4 × 8 S tight screws (P/N B3324080)

Procedure

1. Remove the upper and lower drawers.
2. Remove the three screws holding the desk rear cover and then the cover.
3. Pass the desk dehumidifier cable to the machine rear through the cable hole in the machine right.
4. Attach the desk dehumidifier using the two M4 × 8 S tight screws.

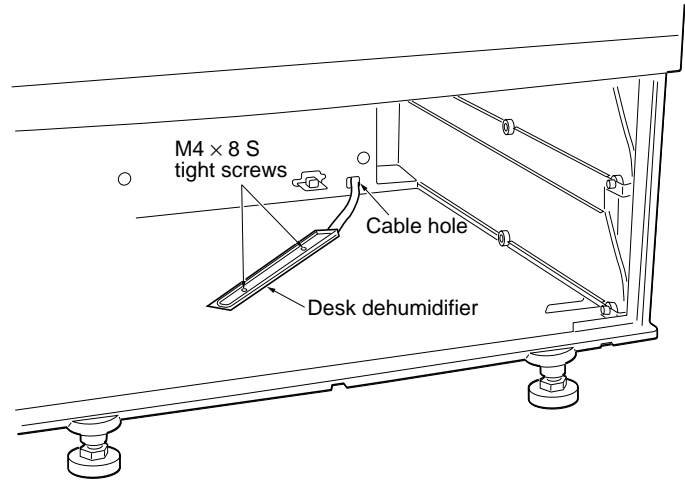

Figure 1-2-2

5. Insert the desk dehumidifier connector into the connector of the main harness.
6. Tidy up the desk dehumidifier cable using the wire saddle and route the cable while clipping the wire saddles into the holes in the rear frame.
7. Refit all removed parts.

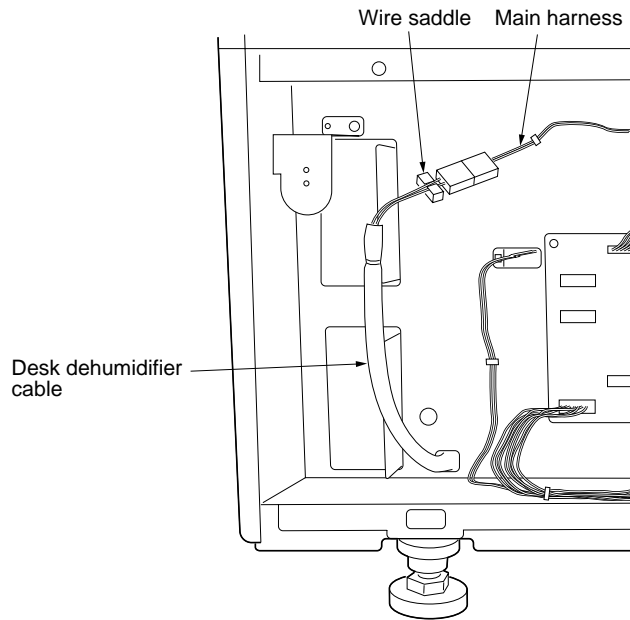

Figure 1-2-3

1-3-1 Paper misfeed detection

(1) Paper misfeed indication

When a paper jam occurs, the machine immediately stops operation. The operation unit of the copier shows a jam message and the jam location.

To reset the paper misfeed detection, open and close the desk left cover to turn the desk safety switch off and on.

(2) Paper misfeed detection conditions

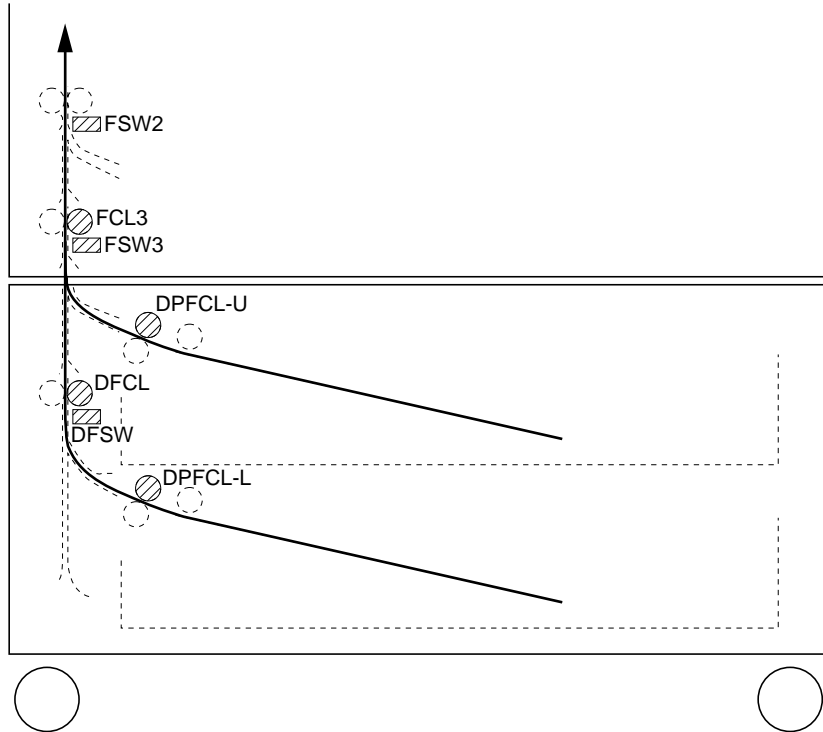
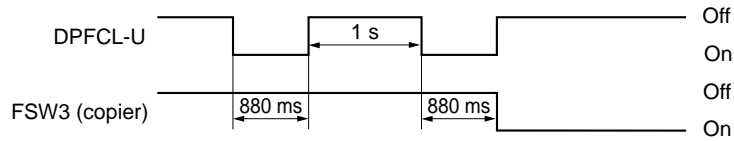

Figure 1-3-1 Paper feed desk

- No paper feed from desk upper drawer (jam code 12)

Feed switch 3 (FSW3) of the copier does not turn on within 880 ms of the desk upper paper feed clutch (DPFCL-U) turning on; the clutch is then held off for 1 s and turned back on, but the switch again fails to turn on within 880 ms of the retry.



Timing chart 1-3-1

- No paper feed from desk lower drawer (jam code 13)

The desk feed switch (DFSW) does not turn on within 880 ms of the desk lower paper feed clutch (DPFCL-L) turning on; the clutch is then held off for 1 s and turned back on, but the switch again fails to turn on within 880 ms of the retry.

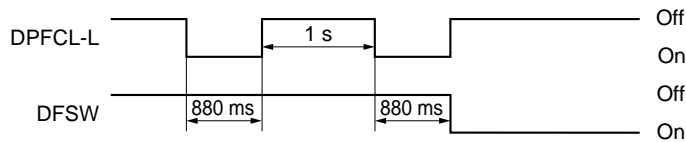

Timing chart 1-3-2

- Jam in copier vertical paper conveying section (jam code 18)
Feed switch 2 (FSW2) of the copier does not turn on within 1203 ms of feed switch 3 (FSW3) of the copier turning on.

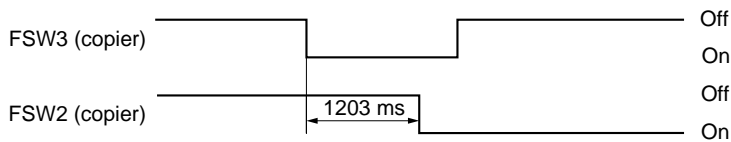

Timing chart 1-3-3

- Jam in paper feed desk vertical paper conveying section (jam code 19)
Feed switch 3 (FSW3) of the copier does not turn on within 888 ms of the desk feed switch (DFSW) turning on.

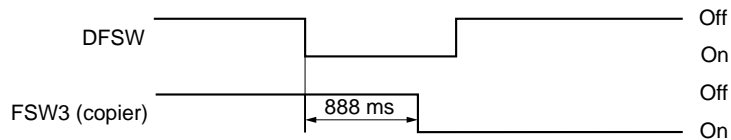

Timing chart 1-3-4

- Multiple sheets in paper feed section (jam code 21)
Feed switch 3 (FSW3) of the copier and the desk feed switch (DFSW) do not turn off within the time required to convey the length of the used paper size plus 635 ms of turning on.

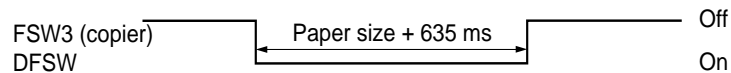

Timing chart 1-3-5

- Multiple sheets in vertical paper conveying section (jam code 22)
Feed switch 2 (FSW2) of the copier does not turn off within 1203 ms of feed switch 3 (FSW3) of the copier turning on.

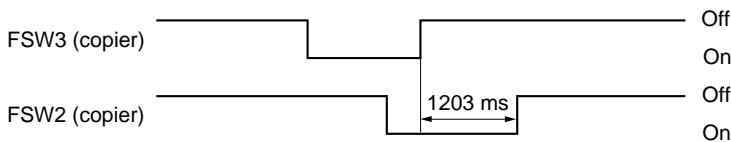

Timing chart 1-3-6

- Feed switch 2 (FSW2) of the copier does not turn off within 1203 ms of feed switch 3 (FSW3) of the copier turning on.

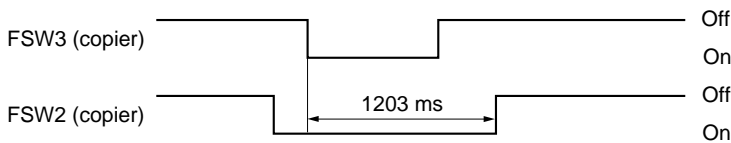

Timing chart 1-3-7

(3) Paper misfeeds

| Problem | Causes/check procedures | Corrective measures |
|---|--|---|
| (1) A paper jam in the paper feed section is indicated during copying (no paper feed from desk upper drawer). Jam code 12 | Paper in the desk upper drawer is extremely curled. | Change the paper. |
| | Check if the paper feed pulley, separation pulley or forwarding pulley of the desk upper drawer is deformed. | Check visually and replace any deformed pulleys. |
| | Broken copier feed switch 3 actuator. | Check visually and replace feed switch 3 if the actuator is broken. |
| | Defective copier feed switch 3. | Run maintenance item U031 and turn feed switch 3 on and off manually. Replace feed switch 3 if indication of the corresponding switch on the operation panel is not displayed in reverse. |
| | Check if the desk upper paper feed clutch malfunctions. | Run maintenance item U247 and select the desk upper paper feed clutch on the operation panel to be turned on and off. Check the status and remedy if necessary. |
| | Electrical problem with the desk upper paper feed clutch. | Check (see page 1-3-7). |
| (2) A paper jam in the paper feed section is indicated during copying (no paper feed from desk lower drawer). Jam code 13 | Paper in the desk lower drawer is extremely curled. | Change the paper. |
| | Check if the paper feed pulley, separation pulley or forwarding pulley of the desk lower drawer is deformed. | Check visually and replace any deformed pulleys. |
| | Broken desk feed switch actuator. | Check visually and replace the desk feed switch if the actuator is broken. |
| | Defective desk feed switch. | With 5 V DC present at CN2-8 on the desk main PCB, check if CN2-7 on the desk main PCB goes low when the desk feed switch is turned on. If not, replace the desk feed switch. |
| | Check if the desk lower paper feed clutch malfunctions. | Run maintenance item U247 and select the desk lower paper feed clutch on the operation panel to be turned on and off. Check the status and remedy if necessary. |
| | Electrical problem with the desk lower paper feed clutch. | Check (see page 1-3-7). |
| (3) A paper jam in the paper feed section is indicated during copying (jam in copier vertical paper conveying section). Jam code 18 | Broken copier feed switch 2 actuator. | Check visually and replace feed switch 2 if the actuator is broken. |
| | Defective copier feed switch 2. | Run maintenance item U031 and turn feed switch 2 on and off manually. Replace feed switch 2 if indication of the corresponding switch on the operation panel is not displayed in reverse. |

| Problem | Causes/check procedures | Corrective measures |
|---|---|---|
| (4) A paper jam in the paper feed section is indicated during copying (jam in paper desk vertical paper conveying section). Jam code 19 | Broken copier feed switch 3 actuator. | Check visually and replace feed switch 3 if the actuator is broken. |
| | Defective copier feed switch 3. | Run maintenance item U031 and turn feed switch 3 on and off manually. Replace feed switch 3 if indication of the corresponding switch on the operation panel is not displayed in reverse. |
| | Check if the desk lower paper feed clutch malfunctions. | Run maintenance item U247 and select the desk lower paper feed clutch on the operation panel to be turned on and off. Check the status and remedy if necessary. |
| | Electrical problem with the desk lower paper feed clutch. | Check (see page 1-3-7). |
| | Check if the desk feed clutch malfunctions. | Run maintenance item U247 and select the desk feed clutch on the operation panel to be turned on and off. Check the status and remedy if necessary. |
| | Electrical problem with the desk feed clutch. | Check (see page 1-3-7). |
| | Check if the desk feed rollers or pulleys are soiled with paper powder. | Check and clean with isopropyl alcohol if soiled. |
| (5) A paper jam in the paper feed section is indicated during copying (multiple sheets in paper feed section). Jam code 21 | Check if the desk feed rollers or pulleys are soiled with paper powder. | Check and clean with isopropyl alcohol if soiled. |
| (6) A paper jam in the paper feed section is indicated during copying (multiple sheets in copier vertical conveying section). Jam code 22 | Check if the copier feed rollers or pulleys are soiled with paper powder. | Check and clean with isopropyl alcohol if soiled. |

1-3-2 Self-diagnosis

(1) Self-diagnostic function

When a problem is detected in the paper feed desk, copying is disabled and the problem displayed on the operation unit of the copier as a code consisting of "C" followed by a number between 0420 and 2600, indicating the nature of the problem. After removing the problem, the self-diagnostic function can be reset by turning the desk safety switch off and back on.

(2) Self diagnostic codes

| Code | Contents | Remarks | |
|-------|---|---|--|
| | | Causes | Check procedures/corrective measures |
| C0420 | <p>Communication problem An error code from the paper feed desk is detected eight times in succession. No communication: there is no reply after 3 retries. Abnormal communication: a communication error (parity or checksum error) is detected five times in succession.</p> | Poor contact of the connector terminals. | Check the connection of connectors CN3 on the copier main PCB and CN5 on the desk main PCB, and the continuity across the connector terminals. Remedy or replace if necessary. |
| | | Defective copier main PCB. | Replace the copier main PCB and check for correct operation. |
| | | Defective desk main PCB. | Replace the desk main PCB and check for correct operation. |
| C1030 | <p>Desk upper lift motor problem When the upper drawer of the paper feed desk is inserted, the desk upper lift limit switch does not turn on within 6 s of the desk upper lift motor turning on and the desk upper lift limit switch does not turn on by turning off the desk upper lift motor for 200 ms and retrying twice. During copying, the desk upper lift limit switch does not turn on within 200 ms of the desk upper lift motor turning on.</p> | Broken gears or couplings of the desk upper lift motor. | Replace the desk upper lift motor. |
| | | Defective desk upper lift motor. | Check for continuity across the coil. If none, replace the desk upper lift motor. |
| | | Poor contact of the desk upper lift motor connector terminals. | Reinsert the connector. Also check for continuity within the connector cable. If none, repair or replace the cable. |
| | | Defective desk upper lift limit switch. | Check if CN1-5 on the desk main PCB goes low when the desk upper lift limit switch is turned off. If not, replace the desk upper lift limit switch. |
| | | Poor contact of the desk upper lift limit switch connector terminals. | Reinsert the connector. Also check for continuity within the connector cable. If none, repair or replace the cable. |

| Code | Contents | Remarks | |
|-------|---|--|---|
| | | Causes | Check procedures/corrective measures |
| C1040 | Desk lower lift motor problem When the lower drawer of the paper feed desk is inserted, the desk lower lift limit switch does not turn on within 6 s of the desk lower lift motor turning on and the desk lower lift limit switch does not turn on by turning off the desk lower lift motor for 200 ms and retrying twice. During copying, the desk lower lift limit switch does not turn on within 200 ms of the desk lower lift motor turning on. | Broken gears of couplings of the desk lower lift motor. | Replace the desk lower lift motor. |
| | | Defective desk lower lift motor. | Check for continuity across the coil. If none, replace the desk lower lift motor. |
| | | Poor contact of the desk lower lift motor connector terminals. | Reinsert the connector. Also check for continuity within the connector cable. If none, repair or replace the cable. |
| | | Defective desk lower lift limit switch. | Check if CN1-7 on the desk main PCB goes low when the desk lower lift limit switch is turned off. If not, replace the desk lower lift limit switch. |
| | | Poor contact of the desk lower lift limit switch connector terminals. | Reinsert the connector. Also check for continuity within the connector cable. If none, repair or replace the cable. |
| C1170 | Paper feed desk incorrect type problem Desk for the printer is installed. | Desk for the printer is installed. | Replace the desk for the copier. |
| C2600 | Desk drive motor problem No pulse is input within 500 ms of the start-up. No pulse is input within 100 ms of the previous pulse input. | Defective desk drive motor PCB. | Replace the desk drive motor PCB and check for correct operation. |
| | | Desk drive motor does not rotate correctly (the motor is over-loaded). | Check the gears and remedy if necessary. |
| | | Poor contact in the desk drive motor connector terminals. | Reinsert the connector. Also check for continuity within the connector cable. If none, remedy or replace the cable. |

1-3-3 Electrical problems

| Problem | Causes | Check procedures/corrective measures |
|---|--|--|
| (1) The paper feed desk does not operate when the copier print key is pressed. | Poor contact of the signal cable connector terminals between the paper feed desk and the copier. | Reinsert the connector. Also check for continuity within the connector cable. If none, repair or replace the cable. |
| | Defective desk safety switch. | Check for continuity across the contacts. If none, replace the desk safety switch. |
| (2) The desk drive motor does not operate. | Poor contact of the desk drive motor connector terminals. | Reinsert the connector. Also check for continuity within the connector cable. If none, repair or replace the cable. |
| | Broken desk drive motor gear. | Check visually and replace the desk drive motor if necessary. |
| | Defective desk drive motor. | Check if the desk drive motor operates when CN4-6 on the desk main PCB goes low. If not, replace the desk drive motor. |
| | Defective desk main PCB. | Check if CN4-6 on the desk main PCB goes low when the desk drive motor is operated in maintenance item U247. If not, replace the desk main PCB. |
| (3) The desk upper paper feed clutch does not operate. | Broken desk upper paper feed clutch coil. | Check for continuity across the coil. If none, replace the desk upper paper feed clutch. |
| | Poor contact of the desk upper paper feed clutch connector terminals. | Reinsert the connector. Also check for continuity within the connector cable. If none, repair or replace the cable. |
| | Defective desk main PCB. | Check if CN1-14 on the desk main PCB goes low when the desk upper paper feed clutch is operated in maintenance item U247. If not, replace the desk main PCB. |
| (4) The desk lower paper feed clutch does not operate. | Broken desk lower paper feed clutch coil. | Check for continuity across the coil. If none, replace the desk lower paper feed clutch. |
| | Poor contact of the desk lower paper feed clutch connector terminals. | Reinsert the connector. Also check for continuity within the connector cable. If none, repair or replace the cable. |
| | Defective desk main PCB. | Check if CN1-13 on the desk main PCB goes low when the desk lower paper feed clutch is operated in maintenance item U247. If not, replace the desk main PCB. |
| (5) The desk feed clutch does not operate. | Broken desk feed clutch coil. | Check for continuity across the coil. If none, replace the desk feed clutch. |
| | Poor contact of the desk feed clutch connector terminals. | Reinsert the connector. Also check for continuity within the connector cable. If none, repair or replace the cable. |
| | Defective desk main PCB. | Check if CN2-1 on the desk main PCB goes low when the desk feed clutch is operated in maintenance item U247. If not, replace the desk main PCB. |

| Problem | Causes | Check procedures/corrective measures |
|--|---|--|
| (6) The desk upper lift motor does not operate. | Broken desk upper lift motor coil. | Check for continuity across the coil. If none, replace the desk upper lift motor. |
| | Poor contact of the desk upper lift motor connector terminals. | Reinsert the connector. Also check for continuity within the connector cable. If none, repair or replace the cable. |
| | Defective desk main PCB. | Check if 24 V DC is output across CN2-5 (-) and CN2-6 (+) on the desk main PCB right after the desk upper drawer is installed. If not, replace the desk main PCB. |
| (7) The desk lower lift motor does not operate. | Broken desk lower lift motor coil. | Check for continuity across the coil. If none, replace the desk lower lift motor. |
| | Poor contact of the desk lower lift motor connector terminals. | Reinsert the connector. Also check for continuity within the connector cable. If none, repair or replace the cable. |
| | Defective desk main PCB. | Check if 24 V DC is output across CN2-3 (-) and CN2-4 (+) on the desk main PCB right after the desk lower drawer is installed. If not, replace the desk main PCB. |
| (8) The size of paper in the upper drawer is not displayed correctly. | Poor contact of the desk upper paper length switch connector terminals. | Reinsert the connector. Also check for continuity within the connector cable. If none, repair or replace the cable. |
| | Poor contact of the desk upper paper width switch connector terminals. | Reinsert the connector. Also check for continuity within the connector cable. If none, repair or replace the cable. |
| | Defective desk upper paper length switch. | Check if CN3-7 on the desk main PCB goes low when the desk upper paper length switch is turned on. If not, replace the desk upper paper length switch. |
| | Defective desk upper paper width switch. | Check for continuity between CN3-9 and CN3-1, CN3-2, and CN3-3 on the desk main PCB. If the continuity is unaffected by movement of the width guides in the upper drawer (i.e. either remains present or remains absent), then replace the desk upper paper width switch. |
| (9) The size of paper in the lower drawer is not displayed correctly. | Poor contact of the desk lower paper length switch connector terminals. | Reinsert the connector. Also check for continuity within the connector cable. If none, repair or replace the cable. |
| | Poor contact of the desk lower paper width switch connector terminals. | Reinsert the connector. Also check for continuity within the connector cable. If none, repair or replace the cable. |
| | Defective desk lower paper length switch. | Check if CN3-8 on the desk main PCB goes low when the desk lower paper length switch is turned on. If not, replace the desk lower paper length switch. |
| | Defective desk lower paper width switch. | Check for continuity between CN3-10 and CN3-4, CN3-5, and CN3-6 on the desk main PCB. If the continuity is unaffected by movement of the width guides in the lower drawer (i.e. either remains present or remains absent), then replace the desk lower paper width switch. |

| Problem | Causes | Check procedures/corrective measures |
|---|---|---|
| (10) The message requesting covers to be closed is displayed when the desk left cover is closed. | Poor contact of the desk safety switch connector terminals. | Reinsert the connector. Also check for continuity within the connector cable. If none, repair or replace the cable. |
| | Defective desk safety switch. | Check for continuity across the contacts. If there is no continuity when the desk safety switch is on, replace it. |
| (11) Others. | Wiring is broken, shorted or makes poor contact. | Check for continuity. If none, repair. |
| | Noise. | Locate the source of noise and remove. |

1-3-4 Mechanical problems

| Problem | Causes/check procedures | Corrective measures |
|--|--|---|
| (1) No paper feed. | Check if the surfaces of the following rollers and pulleys are soiled with paper powder: forwarding pulley, paper feed pulley, separation pulley, desk feed roller and desk feed pulley. | Clean with isopropyl alcohol. |
| | Check if the paper feed pulley or separation pulley is deformed. | Replace (see page 1-4-2). |
| | Check if the forwarding pulley is deformed. | Replace (see page 1-4-2). |
| | Electrical problem with the following electromagnetic clutches: desk upper/lower paper feed clutches and desk feed clutch. | See pages 1-3-7. |
| (2) Skewed paper feed. | Width guide in the drawer installed incorrectly. | Check the width guide visually and remedy or replace if necessary. |
| | Deformed width guide in the drawer. | Check the width guide visually and remedy or replace if it is deformed. |
| (3) Multiple sheets of paper are fed at one time. | Check if the separation pulley is deformed. | Replace the separation pulley if it is worn (see page 1-4-2). |
| | Check if the paper is curled. | Change the paper. |
| (4) Paper jams. | Check if the paper is excessively curled. | Change the paper. |
| | Deformed guides along the paper conveying path. | Check visually and remedy or replace any deformed guides. |
| (5) Abnormal noise is heard. | Check if the pulleys, rollers and gears operate smoothly. | Grease the bearings and gears. |
| | Check if the desk upper and lower paper feed clutches and the desk feed clutch are installed correctly. | Remedy. |

1-4-1 Precautions for assembly and disassembly

(1) Precautions

- Be sure to turn the main switch off and disconnect the power plug before starting disassembly.
- When handling PCBs, do not touch connectors with bare hands or damage the board.
- Do not touch PCBs containing ICs with bare hands or any object prone to static charge.
- Use the following testers when measuring voltages:

Hioki 3200

Sanwa MD-180C

Sanwa YX-360TR

Beckman TECH300

Beckman DM45

Beckman 330 (capable of measuring RMS values)

Beckman 3030 (capable of measuring RMS values)

Beckman DM850 (capable of measuring RMS values)

Fluke 8060A (capable of measuring RMS values)

Arlec DMM1050

Arlec YF1030C

1-4-2 Paper feed section

(1) Detaching and refitting the forwarding, paper feed and separation pulleys

Replace the forwarding, paper feed and separation pulleys as follows.

Procedure

• Removing the primary paper feed units

1. Remove the upper and lower drawers.
2. Remove the two screws holding the lower front cover and then the cover.
3. Remove the one screw from each of the primary paper feed units and then the units.

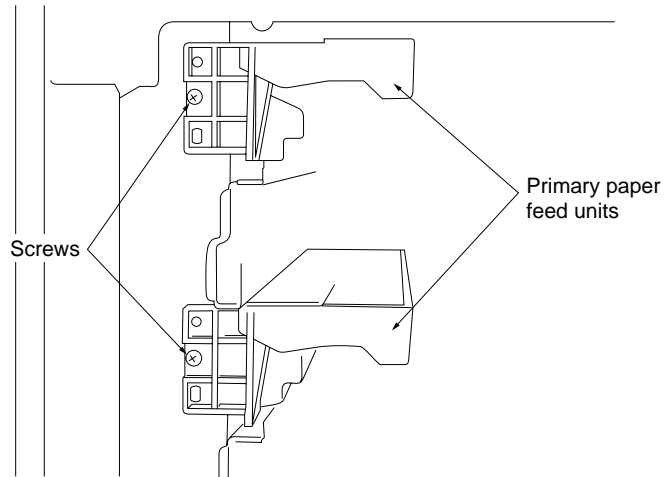

Figure 1-4-1 Detaching the primary paper feed units

• Removing the forwarding pulley

4. Remove the stopper.
5. Raise the forwarding pulley retainer in the direction of the arrow, and remove from the primary paper feed unit.

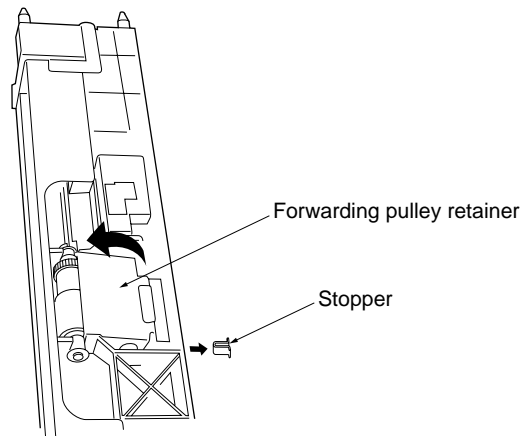

Figure 1-4-2 Detaching the forwarding pulley retainer

6. Remove the stop ring, pull the forwarding pulley shaft in the direction of the arrow, and remove the forwarding pulley.

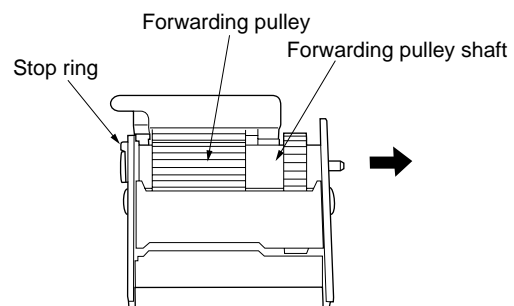

Figure 1-4-3 Detaching the forwarding pulley

- **Removing the paper feed pulley**

7. Remove the two stop rings.
8. Pull the paper feed shaft toward the rear of the primary paper feed unit (in the direction of the arrow) and remove the paper feed pulley and gear.

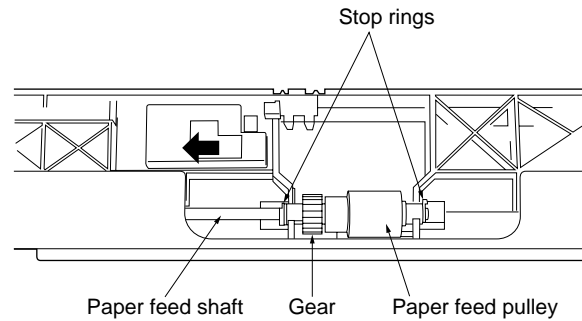

Figure 1-4-4 Detaching the paper feed pulley

- **Removing the separation pulley**

9. Remove the stop ring from the rear of the primary paper feed unit.
10. Pull the separation shaft toward the rear of the machine (in the direction of the arrow) and remove the separation pulley.
11. Replace the forwarding, paper feed and separation pulleys.
12. Refit all removed parts.

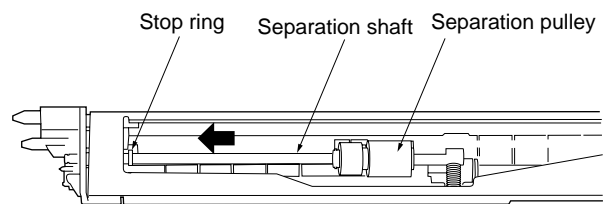

Figure 1-4-5 Detaching the separation pulley

Cautions:

- When fitting the forwarding pulley, orient it correctly as shown in Figure 1-4-6.
- When fitting the paper feed pulley and gear, keep the blue end of the paper feed pulley and the black end of the gear toward the machine rear.

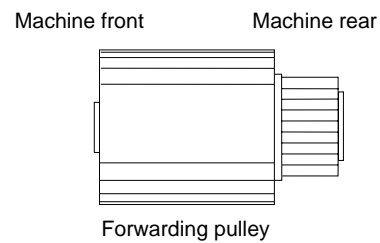

Figure 1-4-6

(2) Replacing the desk upper or lower paper width switches

Replace the desk upper or lower paper width switches as follows.

Caution:

After replacing a desk paper width switch, be sure to perform (4) Adjusting the position of the rack adjuster.

Procedure

1. Remove the drawer.
2. Remove the two screws and 8-pin socket from the rear of the drawer.
3. Detach the 8-pin desk paper width switch connector from the 8-pin socket.
4. Remove the three screws holding the rack adjuster.
5. While raising the drawer lift in the direction of the arrow, remove the rack adjuster.

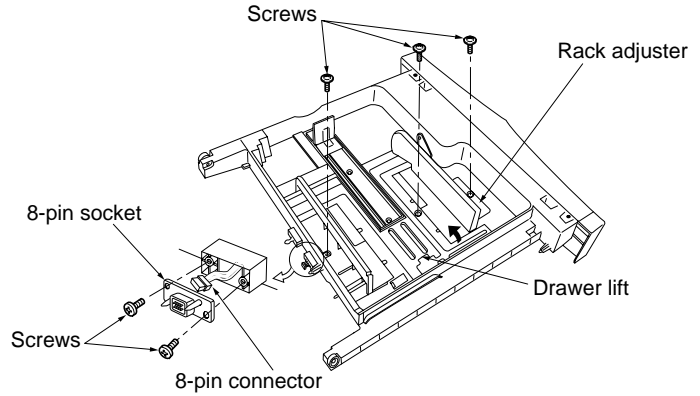

Figure 1-4-7 Detaching the rack adjuster

6. Remove the two screws from the back of the rack adjuster and then the desk paper width switch.

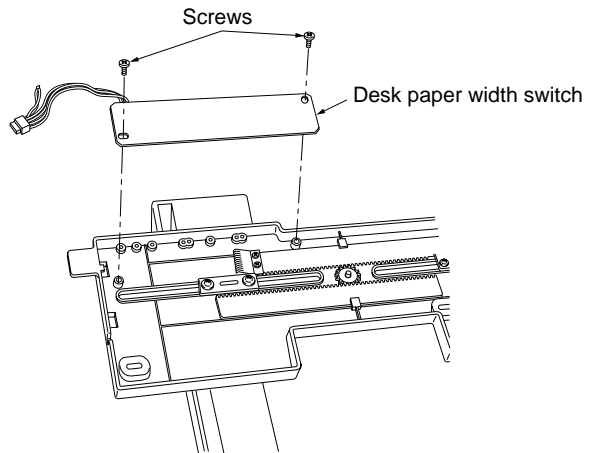

Figure 1-4-8 Detaching the desk paper width switch

7. Apply the specified grease to the printed surface of the new desk paper width switch (shaded area in the diagram) and fit the switch to the rack adjuster.
8. Refit all removed parts.

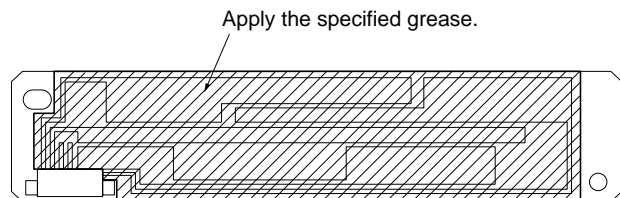

Figure 1-4-9 Desk paper width switch

(3) Replacing the desk feed, upper and lower paper feed clutches

Replace the desk feed, upper and lower paper feed clutches as follows.

Procedure

1. Remove the three screws holding the desk rear cover and then the cover.
2. Remove the cable from the retainer clamp.
3. Remove the three screws holding the retainer and then the retainer.
4. Remove the two screws holding the rear cover left retainer and then the retainer.

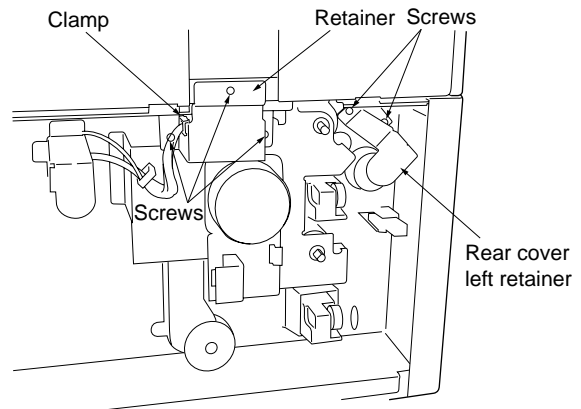
**Figure 1-4-10**

5. Remove the upper and lower stop rings and bearings from the desk upper and lower paper feed clutches.
6. Remove the stop ring from the desk feed clutch.

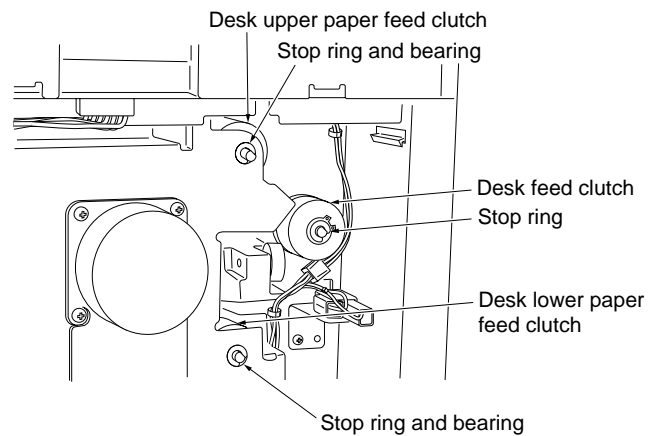
**Figure 1-4-11**

7. Remove the three screws holding the desk drive motor retainer and then the retainer.

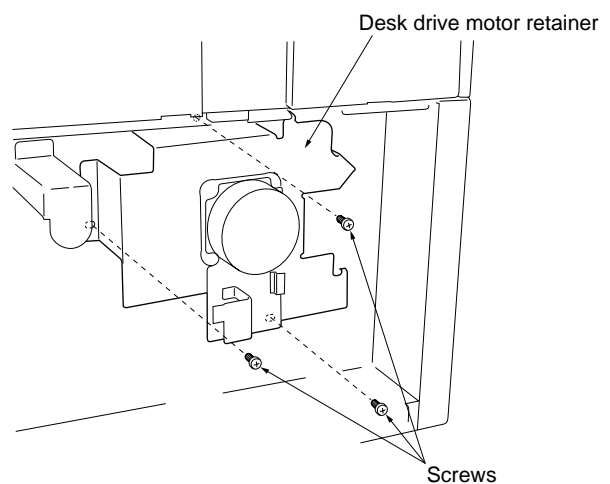
**Figure 1-4-12 Detaching the desk drive motor retainer**

3CC

8. Remove the connectors of the desk feed, upper and lower paper feed clutches and then the clutches.

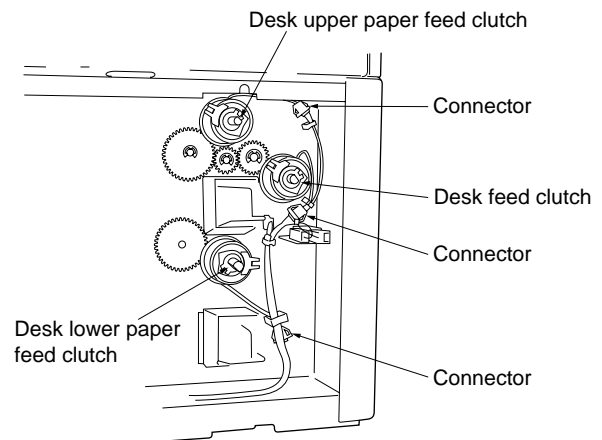

Figure 1-4-13 Detaching the desk feed, upper and lower paper feed clutches

9. Replace the clutches.
10. Refit all removed parts.

Caution:

When fitting the clutches, be sure to refit the whirl-stops.

(4) Adjusting the position of the rack adjuster

Perform the following adjustment if there is a regular error between the center lines of the copy image and the original on the paper fed from the drawer.

Procedure

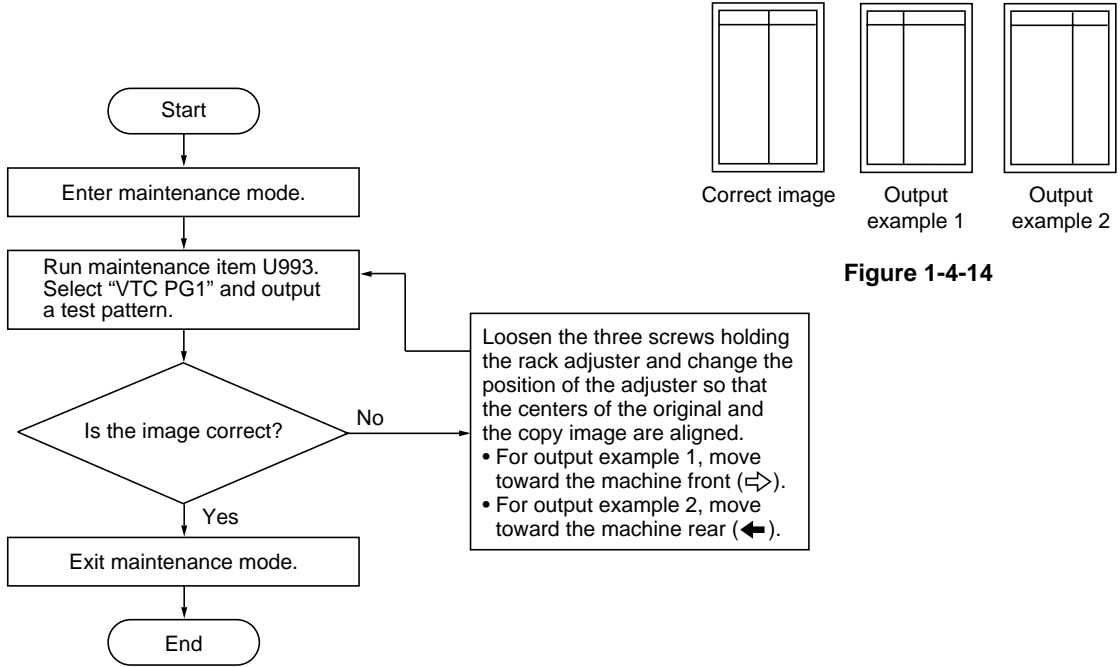

Figure 1-4-14

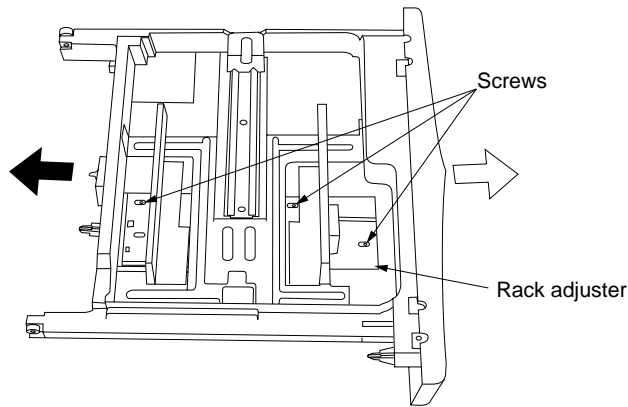

Figure 1-4-15 Adjusting the position of the rack adjuster

(5) Adjusting the amount of slack

Perform the following adjustment if the leading edge of the copy image is missing or varies randomly, or if the copy paper is Z-folded.

Procedure

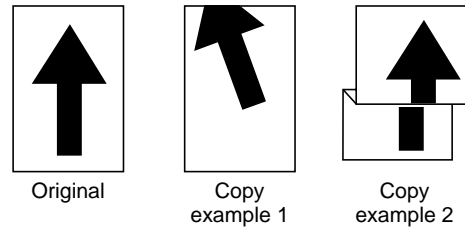
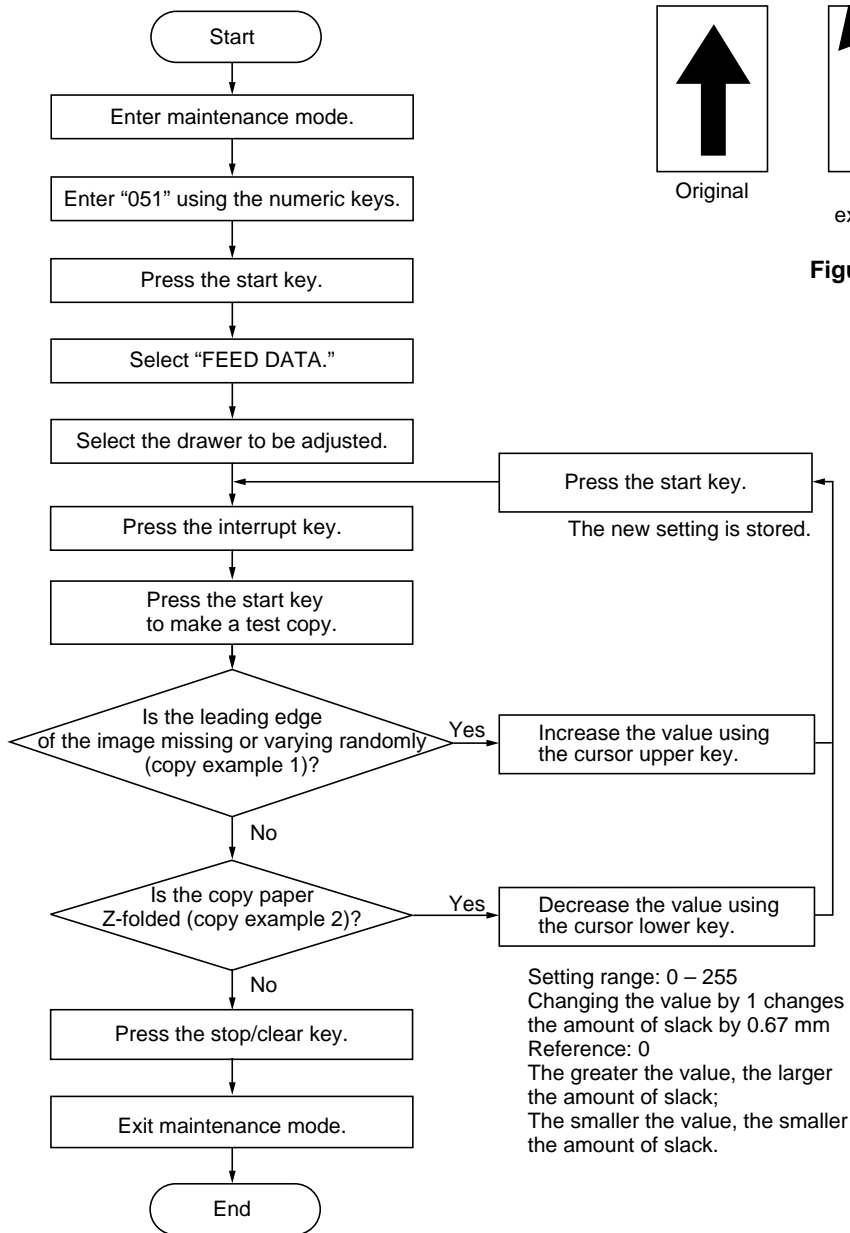

Figure 1-4-16

2-1-1 Mechanical construction

The paper feed desk feeds paper from either of its two drawers to the copier main body. When paper is fed from the lower drawer of the paper feed desk, the desk feed clutch (DFCL) is operated to rotate the desk feed roller and pulley to carry the paper into the copier main body.

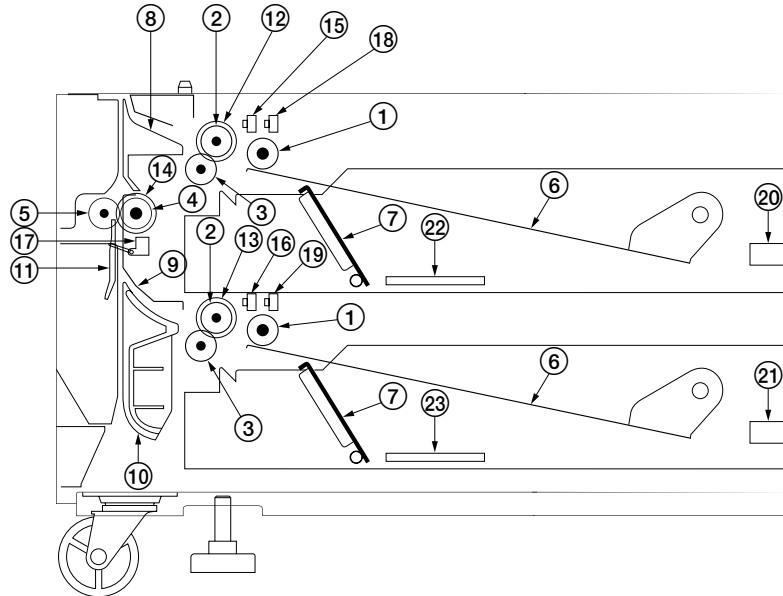

Figure 2-1-1 Paper feed desk

- | | |
|--|--|
| ① Forwarding pulley | ⑬ Desk lower paper feed clutch (DPFCL-L) |
| ② Paper feed pulley | ⑭ Desk feed clutch (DFCL) |
| ③ Separation pulley | ⑮ Desk upper paper switch (DPSW-U) |
| ④ Desk feed roller | ⑯ Desk lower paper switch (DPSW-L) |
| ⑤ Desk feed pulley | ⑰ Desk feed switch (DFSW) |
| ⑥ Drawer lift | ⑱ Desk upper lift limit switch (DLICSW-U) |
| ⑦ Lift operating plate | ⑲ Desk lower lift limit switch (DLICSW-L) |
| ⑧ Desk upper feed guide | ⑳ Desk upper paper length switch (DPLSW-U) |
| ⑨ Desk middle feed guide | ㉑ Desk lower paper length switch (DPLSW-L) |
| ⑩ Desk lower feed guide | ㉒ Desk upper paper width switch (DPWSW-U) |
| ⑪ Desk feed guide | ㉓ Desk lower paper width switch (DPWSW-L) |
| ⑫ Desk upper paper feed clutch (DPFCL-U) | |

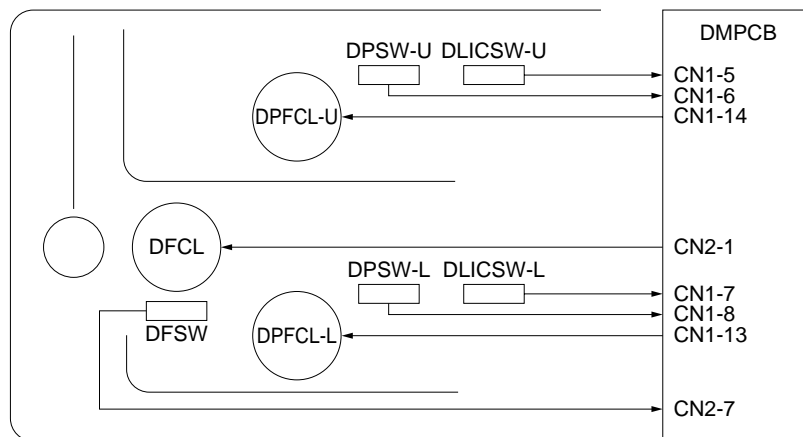
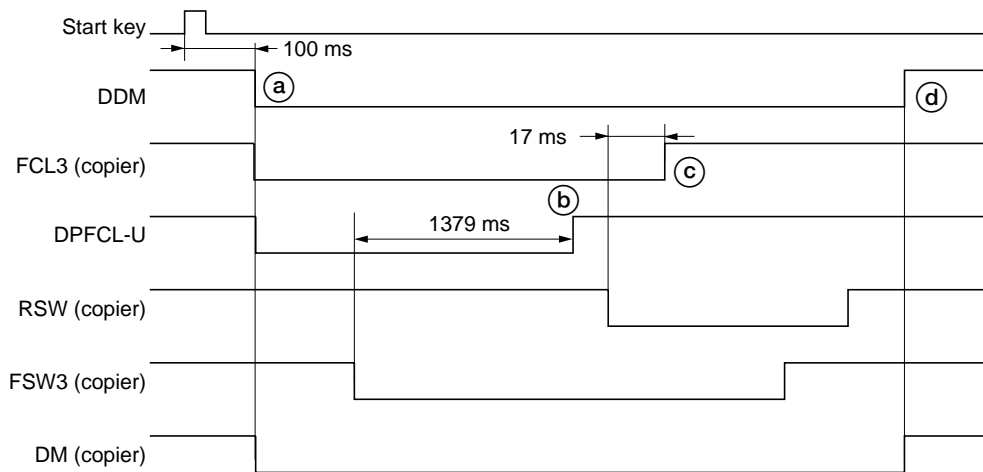

Figure 2-1-2 Paper feed desk block diagram

• Paper feed from the desk upper drawer



Automatic copy density control;
A3/11" × 17" paper; magnification of 100%

Timing chart 2-1-1 Paper feed from the desk upper drawer

- Ⓐ 100 ms after the start key is pressed, the desk drive motor (DDM) turns on at the same time as the drive motor (DM) turns on, starting the drive for the paper feed desk. The desk upper paper feed clutch (DPFCL-U) turns on to start rotating the forwarding pulley and paper feed pulley to start paper feed from the upper drawer.
- Ⓑ 1379 ms after the leading edge of the paper turns the feed switch 3 (FSW3) on, the desk upper paper feed clutch (DPFCL-U) turns off.
- Ⓒ 17 ms after the leading edge of the paper turns the registration switch (RSW) on, feed clutch 3 (FCL3) turns off.
- Ⓓ The desk drive motor (DDM) turns off at the same time as the drive motor (DM) turns off to stop the drive for the paper feed desk.

• Paper feed from the desk lower drawer

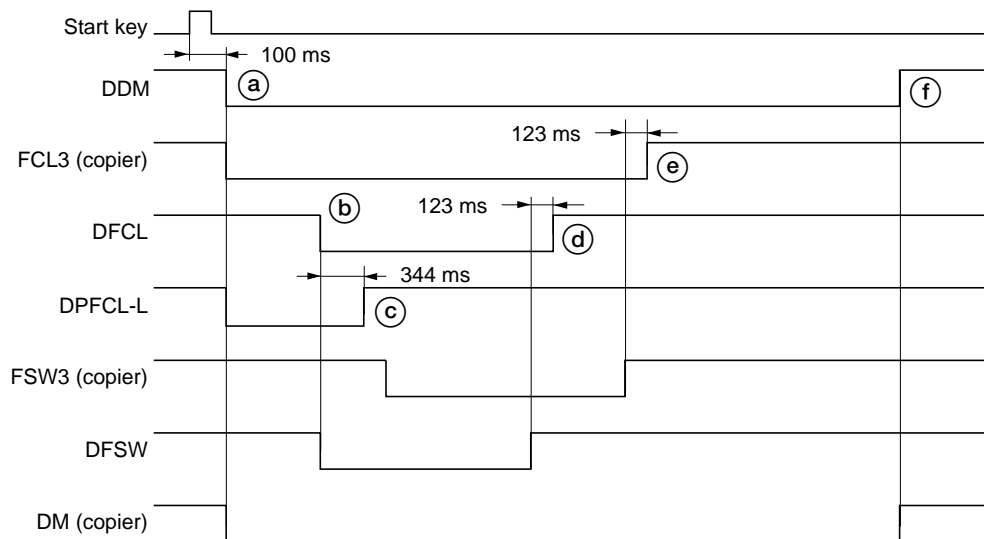

Manual copy density control;
A4/11" × 8¹/₂" paper; magnification of 100%

Timing chart 2-1-2 Paper feed from the desk lower drawer

- Ⓐ 100 ms after the start key is pressed, the desk drive motor (DDM) turns on at the same time as the drive motor (DM) turns on, starting the drive for the paper feed desk. The desk lower paper feed clutch (DPFCL-L) turns on to start rotating the forwarding pulley and paper feed pulley to start paper feed from the lower drawer.
- Ⓑ At the same time as the leading edge of the paper turns the desk feed switch (DFSW) on, the desk feed clutch (DFCL) turns on to rotate the desk feed roller to convey the paper to the copier.
- Ⓒ 344 ms after the desk feed switch (DFSW) turns on, the desk lower paper feed clutch (DPFCL-L) turns off.
- Ⓓ 123 ms after the trailing edge of the paper turns the desk feed switch (DFSW) off, the desk feed clutch (DFCL) turns off.
- Ⓔ 123 ms after the trailing edge of the paper turns feed switch 3 (FSW3) off, feed clutch 3 (FCL3) turns off.
- Ⓕ The desk drive motor (DDM) turns off at the same time as the drive motor (DM) turns off to stop the drive for the paper feed desk.

2-2-1 Electrical parts layout

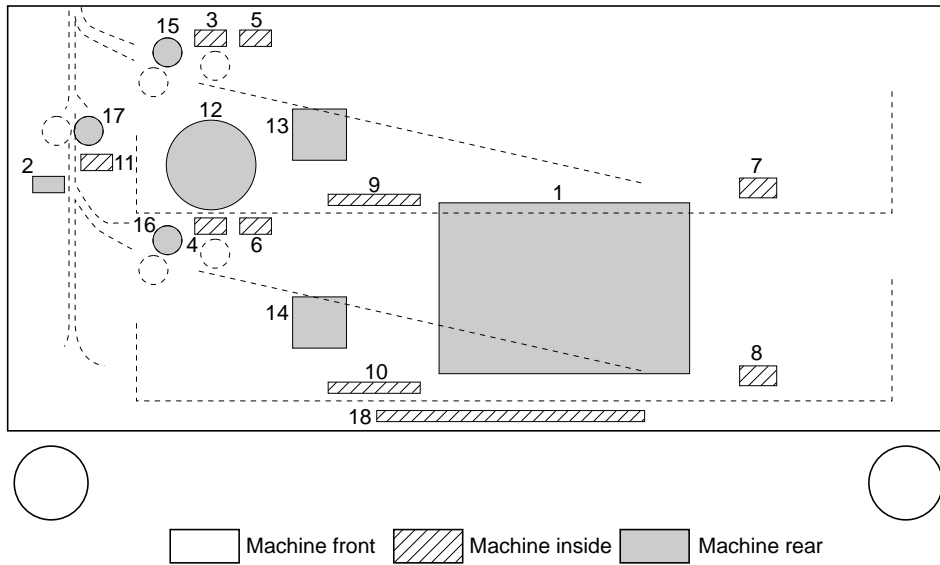

Figure 2-2-1 Layout of electrical parts

- 1. Desk main PCB (DMPCB) Controls electrical parts.
- 2. Desk safety switch (DSSW) Breaks the safety circuit when the desk left cover is opened, and resets paper jam detection.
- 3. Desk upper paper switch (DPSW-U) Detects the presence of paper in the desk upper drawer.
- 4. Desk lower paper switch (DPSW-L) Detects the presence of paper in the desk lower drawer.
- 5. Desk upper lift limit switch (DLICSW-U) Detects the desk upper drawer lift reaching the upper limit.
- 6. Desk lower lift limit switch (DLICSW-L) Detects the desk lower drawer lift reaching the upper limit.
- 7. Desk upper paper length switch (DPLSW-U) Detects the length of paper in the desk upper drawer.
- 8. Desk lower paper length switch (DPLSW-L) Detects the length of paper in the desk lower drawer.
- 9. Desk upper paper width switch (DPWSW-U) Detects the width of paper in the desk upper drawer.
- 10. Desk lower paper width switch (DPWSW-L) Detects the width of paper in the desk lower drawer.
- 11. Desk feed switch (DFSW) Controls the desk lower paper feed clutch.
- 12. Desk drive motor (DDM) Drives the paper feed desk.
- 13. Desk upper lift motor (DCLM-U) Drives the desk upper drawer lift.
- 14. Desk lower lift motor (DCLM-L) Drives the desk lower drawer lift.
- 15. Desk upper paper feed clutch (DPFCL-U) ... Primary paper feed from the desk upper drawer.
- 16. Desk lower paper feed clutch (DPFCL-L) Primary paper feed from the desk lower drawer.
- 17. Desk feed clutch (DFCL) Conveys paper to the copier.
- 18. Desk dehumidifier* (DDH) Dehumidifies paper.

* Service part.

2-3-1 Desk main PCB

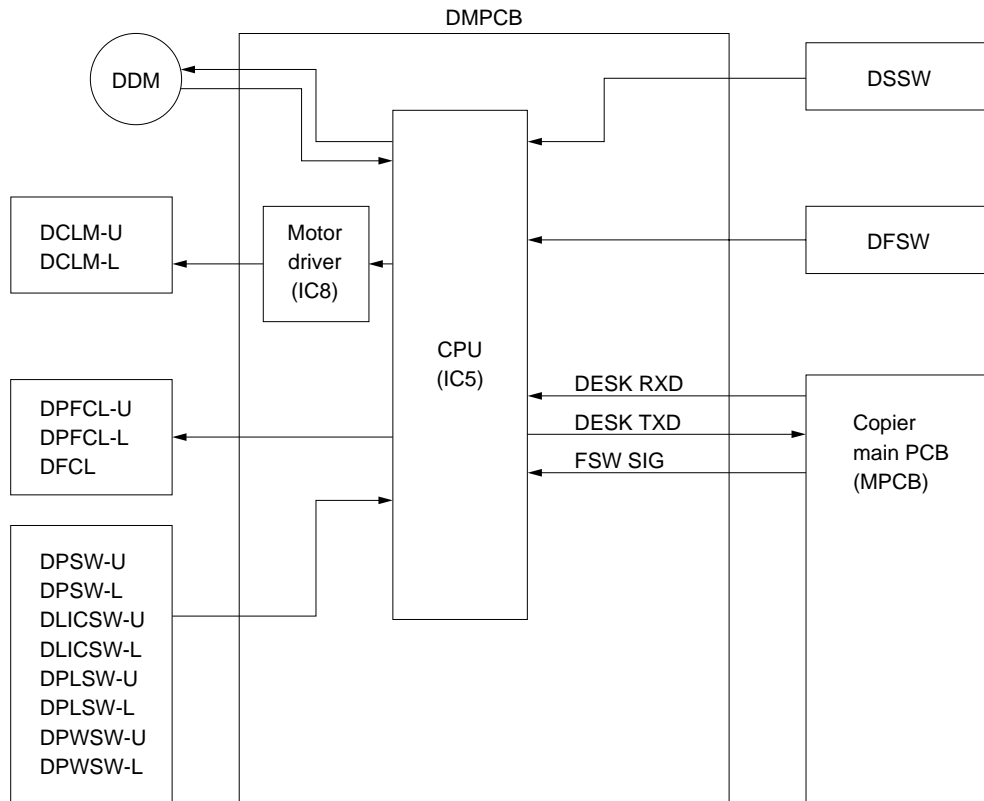

Figure 2-3-1 Desk main PCB block diagram

The desk main PCB (DMPCB) is controlled from the copier main PCB (MPCB) which controls the inputs from and outputs to the motors, clutches and switches on the paper feed desk through the CPU IC5 serially via two-way serial/parallel 8-bit data conversion.

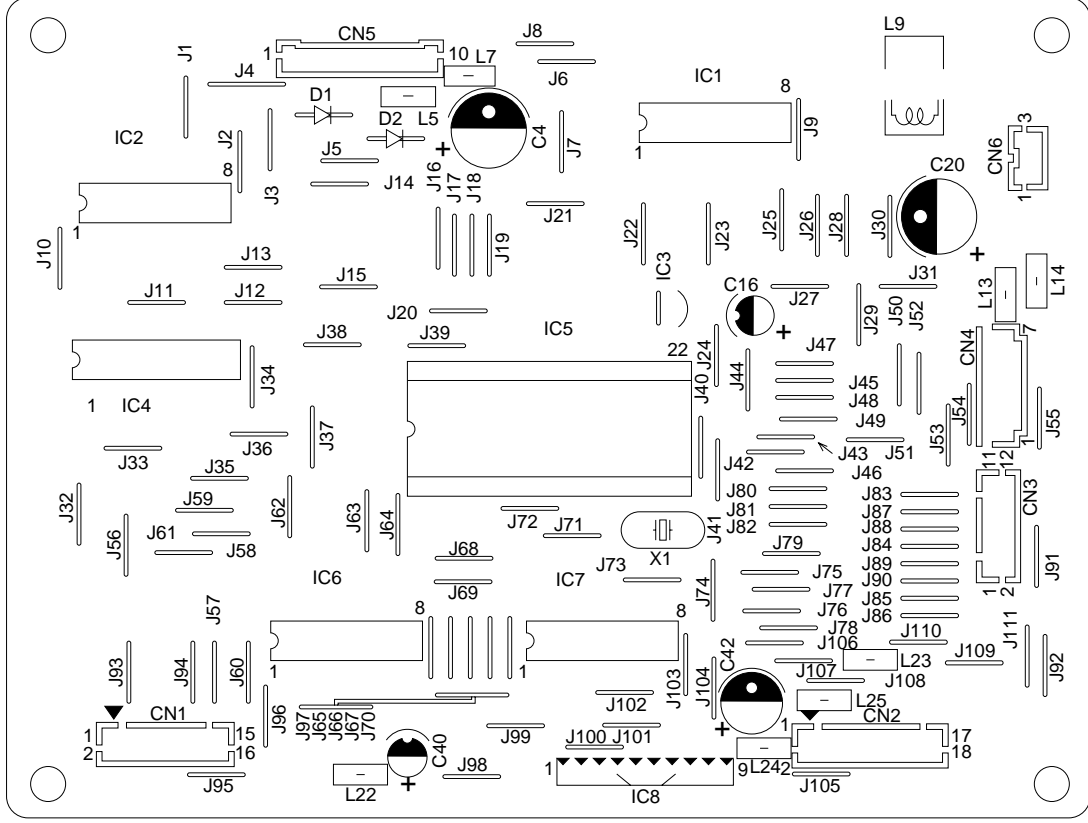
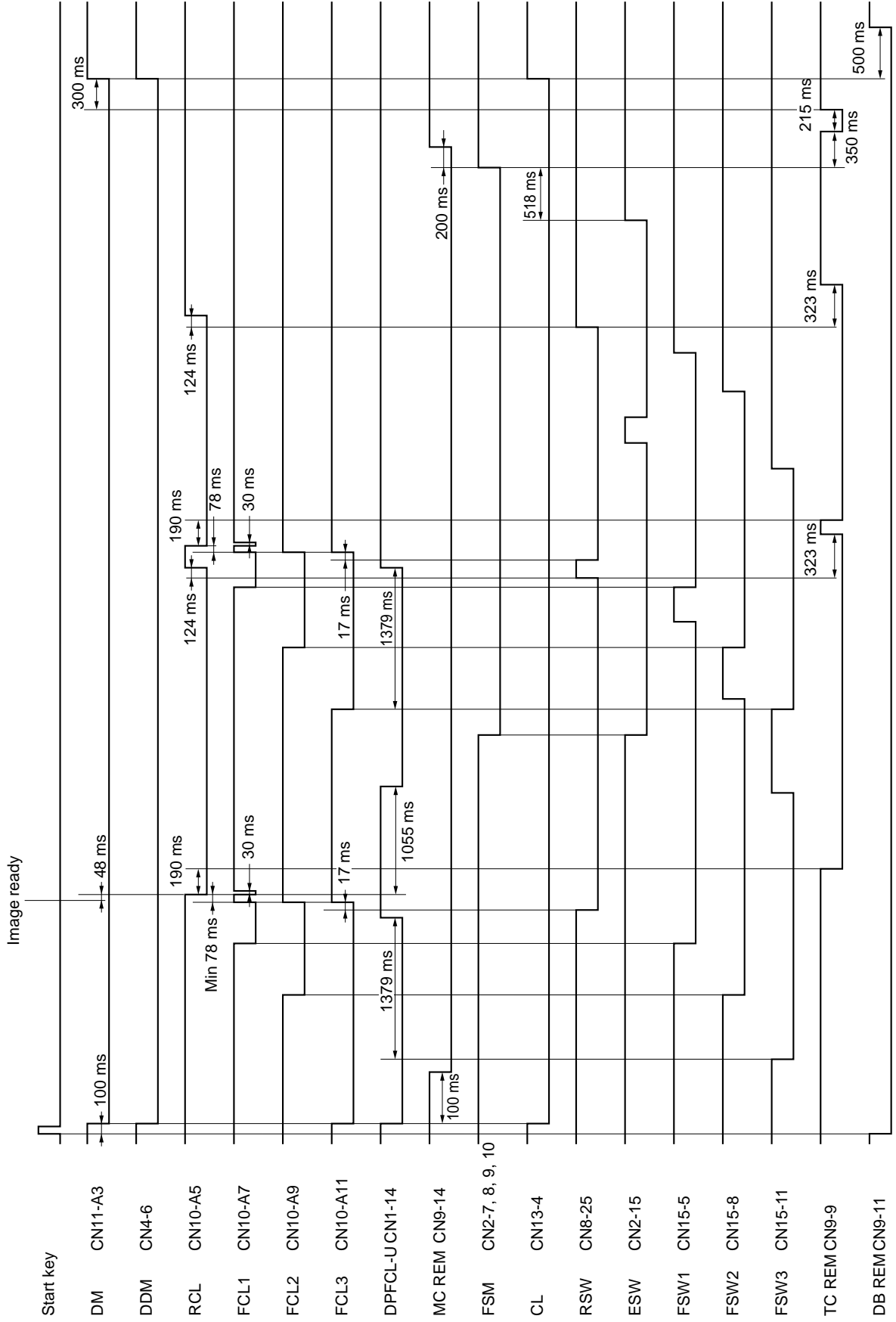

Figure 2-3-2

| Terminals (CN) | | Voltage | Remarks |
|----------------|------|------------------|---|
| 1-1 | 1-9 | 5 V DC | 5 V DC supply for DLICSW-U, output |
| 1-2 | 1-10 | 5 V DC | 5 V DC supply for DPSW-U, output |
| 1-3 | 1-11 | 5 V DC | 5 V DC supply for DLICSW-L, output |
| 1-4 | 1-12 | 5 V DC | 5 V DC supply for DPSW-L, output |
| 1-5 | 1-9 | 5/0 V DC | DLICSW-U on/off, input |
| 1-6 | 1-10 | 0/5 V DC | DPSW-U on/off, input |
| 1-7 | 1-11 | 5/0 V DC | DLICSW-L on/off, input |
| 1-8 | 1-12 | 0/5 V DC | DPSW-L on/off, input |
| 1-13 | 5-8 | 0/24 V DC | DPFCL-L on/off, input |
| 1-14 | 5-8 | 24 V DC | 24 V DC supply for DPFCL-L, output |
| 1-15 | 5-8 | 0/24 V DC | DPFCL-U on/off, input |
| 1-16 | 5-8 | 24 V DC | 24 V DC supply for DPFCL-U, output |
| 2-1 | 5-8 | 0/24 V DC | DFCL on/off, input |
| 2-2 | 5-8 | 24 V DC | 24 V DC supply for DFCL, output |
| 2-3 | 5-8 | 0/24 V DC | DCLM-L on/off, input |
| 2-4 | 5-8 | 24 V DC | 24 V DC supply for DCLM-L, output |
| 2-5 | 5-8 | 0/24 V DC | DCLM-U on/off, input |
| 2-6 | 5-8 | 24 V DC | 24 V DC supply for DCLM-U, output |
| 2-7 | 2-9 | 0/5 V DC | DFSW on/off, output |
| 2-8 | 2-9 | 5 V DC | 5 V DC supply for DFSW, output |
| 2-15 | 2-13 | 0/5 V DC | Paper level detection switch on/off, input |
| 2-16 | 2-14 | 0/5 V DC | Paper level detection switch on/off, input |
| 2-17 | 2-13 | 0/5 V DC | Paper level detection switch on/off, input |
| 2-18 | 2-14 | 0/5 V DC | Paper level detection switch on/off, input |
| 3-1 | 3-9 | 0/5 V DC | DPWSW-U (DIG0) on/off, input |
| 3-2 | 3-9 | 0/5 V DC | DPWSW-U (DIG1) on/off, input |
| 3-3 | 3-9 | 0/5 V DC | DPWSW-U (DIG2) on/off, input |
| 3-4 | 3-10 | 0/5 V DC | DPWSW-L (DIG0) on/off, input |
| 3-5 | 3-10 | 0/5 V DC | DPWSW-L (DIG1) on/off, input |
| 3-6 | 3-10 | 0/5 V DC | DPWSW-L (DIG2) on/off, input |
| 3-7 | 3-11 | 0/5 V DC | DPLSW-U on/off, input |
| 3-8 | 3-12 | 0/5 V DC | DPLSW-L on/off, input |
| 4-1 | 4-2 | 24 V DC | 24 V DC supply for DDM, output |
| 4-4 | 4-3 | 5 V DC | 5 V DC supply for DDM, output |
| 4-5 | 4-2 | 0/5 V DC (pulse) | Clock signal to DDM, output |
| 4-6 | 4-2 | 0/5 V DC | DDM on/off, output |
| 4-7 | 4-2 | 0/5 V DC | LOCK signal to DDM, input |
| 5-1 | 5-2 | 0/5 V DC | FSW3 on/off from the copier, input |
| 5-3 | 5-2 | 0/5 V DC (pulse) | Serial communication signal to the copier, output |
| 5-5 | 5-4 | 0/5 V DC (pulse) | Serial communication signal to the copier, input |
| 5-6 | 5-7 | 5 V DC | 5 V DC supply, input |
| 5-10 | 5-8 | 24 V DC | 24 V DC supply, input |
| 6-1 | 5-8 | 24/0 V DC | DSSW on/off, input |
| 6-3 | 5-8 | 24 V DC | 24 V DC supply for DSSW, output |

Timing chart No. 1 Continuous copying an A3/11" × 17" original onto two sheets of A3/11" × 17" copy paper from the paper feed desk upper drawer, magnification ratio 100%, auto copy density control



Timing chart No. 2 Copying an A4/11" × 8 1/2" original onto an A4/11" × 8 1/2" copy paper from the paper feed desk lower drawer, magnification ratio 100%, manual copy density control

